

SPC4: IP67 Splash-Proof Cover

Key Features:

- Low Cost
- Easy to Install
- Immersion Protected up to 1 metre
- Impact Resistant
- Fits Most 1/8 DIN Meters
- Non-Ferrous Parts for Longer Life
- Anti-Scratch Coating
- 3 Year Warranty



The SPC4 offers a low cost and robust method of sealing the front of all Intuitive2 and Intuitive4 indicators, along with most other manufacturers' 1/8 DIN size panel meters. The design uses all corrosion-resistant materials for longer life, meaning less maintenance. You can easily fit it to existing installations, or include it as a value-added accessory for new systems.

The panel cutout is the standard hole size for the panel meter, so no changes to the panel are needed. The front window is detachable, permitting adjustments to be made to the panel meter during commissioning and is held firmly in place by two knurled captive screws which resist accidental side or front impact.

The window and the holding frame are both moulded from a high impact resistant material. And, to give good reliability, the female threaded sections are made from marine brass and are moulded deep into the frame itself. Highly flexible and resilient neoprene gaskets firmly bonded to the inner and outer faces of the frame provide the reliable sealing effect, while for excellent clarity and resistance to scratching the covers are coated with a special anti-scruff treatment.

Dimensions:

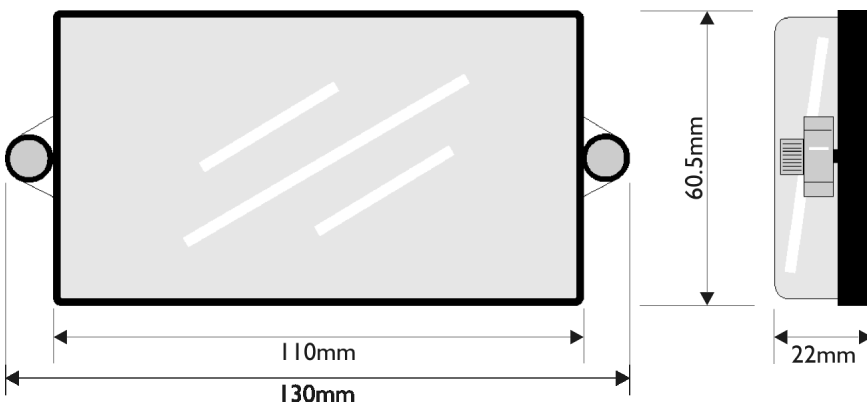

Construction Materials:

Window & Frame = Polycarbonate
Screws = Nickel Plated Marine Brass
Female Threaded Bushes = Marine Brass

Associated Products:



[INT4-L Digital Indicator](#)



[Intuitive-Lite4-L Digital Indicator](#)