

LVDT Signal Conditioner | LVDT Amplifier

Key Features:

- 4.5Vac LVDT Excitation @ 1-5kHz
- Output: 0-5Vdc, 0-10Vdc, 4-20mA, 0-20mA, ± 5 Vdc or ± 10 Vdc
- Environmental Protection: IP65
- Bandwidth: 200Hz max
- Mains & 18-24Vdc Versions
- Selectable Sensitivity
- High Frequency Filtering
- User Selectable Analogue Outputs
- 3 Year Warranty



The LVDT/A & LVDT/D signal conditioners are designed for use specifically with LVDT displacement transducers to provide a wide range of signal conditioning for LVDT transducers.

We can provide 2 versions:

- The LVDT/A for 115/230V AC or 18-24V DC operation.
- The LVDT/D which is DC powered only.

Both the AC and DC versions are based on a common board and are mounted in a light grey ABS case sealed to IP65 standard.

The LVDT signal conditioner provides an excitation voltage of 4.5Vrms with switch selectable frequencies ranging from 1kHz to 5kHz, making it suitable for use with LVDTs from many different manufacturers.

Transducer sensitivities between 20mV and 10V are accommodated by a combination of DIL switch settings and a fine trim potentiometer. Similar arrangements are provided for any 'zero' errors in the transducers and can be used to offset the readings by up to $\pm 35\%$ of full scale.

A wide frequency response is offered, of typically DC to 200Hz. There is an on-board low pass filter which can be switched in to reduce high frequency fluctuations or induced electrical noise, to give stable readings under adverse conditions. A wide range of output options for current, and uni-polar or bi-polar voltage can be configured by DIL switch settings.

We can provide a wide range of suitable LVDT displacement transducers to accompany the LVDT signal conditioner, please speak to our [technical sales team](#).

Industries:

- Automotive
- Agriculture
- Silo and Weighing Industry
- Construction
- Alternative Energy
- Civil Engineering
- Lifting and Handling
- Waste Management

Applications:

- Weighing Platforms
- Vessel Weighing Systems
- Weighbridges
- Conveyor Weighing Systems
- Bridge Structure Monitoring
- Waste Management Systems
- Lifting and Handling
- Monitoring of Anchor Loads
- Truck Load Weight Monitoring
- Skip Weighing System
- Multi-Cell or Multi-Transducer Installations
- Monitoring of Building Foundations
- Force Measurement in Formula Racing
- Silo Weighing
- Measuring the Power Output of a Motor
- Weighbridges

Specification:

	Minimum	Typical	Maximum	Units
Power supply AC LVDT/A only (110/230 V AC) 50-60Hz	99/198	110/230	126/253	Vac
Power supply DC: LVD/A and /D	18	24	28	Vdc
Power supply current DC: (depends on loading)	138	145	150	mA (200R)
Excitation	-	4.5	-	V rms
LVDT Frequency (Selected by Switch 1,2,3,4,5 kHz)	1	-	5	kHz
LVDT Impedance	50	200	-	Ohms
LVDT Sensitivity (switchable)	0.02	-	10	V
Gain Adjustment (Pot – fine adj)	-	-	25	% FSD
Offset Adjustment (Pot – fine adj)	-	-	10	% FSD
Offset Adjustment (Switchable – coarse adj)	-	-	30	% FSD
Output Load (voltage output)	0	-	2	mA
Output Load (current output)	-	-	500	Ohms
Filter cut-off (switchable ranges)	5	-	200	Hz
Zero Temperature Coefficient	-	2	4	$\mu\text{V}/^\circ\text{C}$
Span Temperature Coefficient	-	0.01	0.015	$\%/^\circ\text{C}$
Linearity	-	0.05	0.1	% FSD
Gain Stability- 1st 1000 hours	-	0.2	0.4	% FSD
90 Day Offset Stability	-	6	10	μV
Noise (1kHz / 20Hz filter / DC powered)	-	3	7	mV p-p
Output Options	$\pm 10\text{V}$, $\pm 5\text{V}$, 0 - 10 V, 0 - 5V, 0 - 20mA, 4 -20mA. NB: Current output is link selectable for source or negative sink (common negative or common positive).			
ENVIRONMENTAL				
Operating Temperature	0	-	50	$^\circ\text{C}$
Storage Temperature	-20	-	70	$^\circ\text{C}$
Humidity	95 maximum non condensing			%
PHYSICAL				
Connections	Field screw terminals - 2.5mm ² rising clamp			
Enclosure	ABS case 160 x 80 x 55 sealed to IP65 fitted with 3 off cable glands			
Controls	Gain pot, Offset pot, Coarse gain switches, Coarse offset switches, Filter cut-off switches, Frequency select switch, Output mode switch.			
Environmental Protection	ABS case sealed to IP65			
Dimensions	160 x 80 x 55 (depth)	mm		mm
Safety and EMC				
Safety/Low Voltage Directive	73/23/EEC amended by 93/68/EEC BS EN 61010-1:2001, IEC 1010-1-1990			
EMC Directive	89/336/EEC Basic Standard BS EN 61326:1998			
EMC Emissions	BS EN 55011:1998			
EMC Immunity	BS EN 61000-42:1995 BS EN 61000-4-3:2002 BS EN 61000-4-4:2004 BS EN 61000-4-11:2004			

Options:

- PCB Only Version Available

Dimensions:

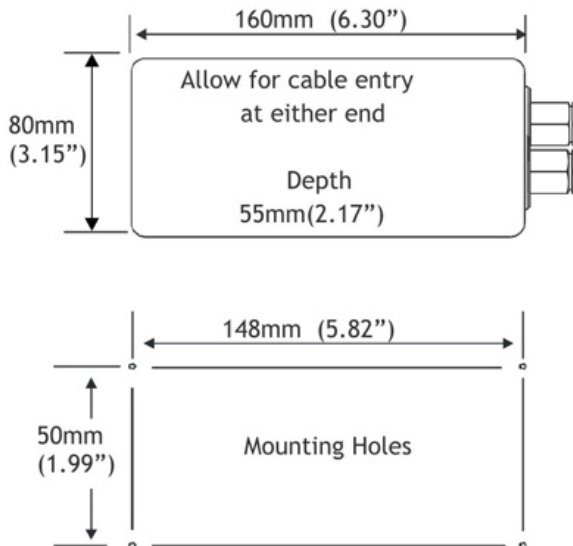

Ordering Codes:

Core Product	Supply Voltage	Example Result
LVDT	99-120/ 198-253Vac	LVDT/A Amplifier
LVDT	18-28Vdc	LVDT/D Amplifier

Associated Products:



[AML/M Miniature LVDT Displacement Sensor](#)



[AML/E Standard LVDT Displacement Sensor](#)



[AML/IE Industrial LVDT Displacement Sensor](#)