

Industrial LVDT Displacement Transducer AML/IE

Key Features:

- Stroke Ranges: $\pm 0.5\text{mm}$ to $\pm 500\text{mm}$
- AC mV/V Output or DC Voltage / Current Output
- Environmental Protection: IP65
- Optional IP68 Submersible & High Temperature Versions
- Stainless Steel Construction
- Core + Extension, Spring-Loaded & Rod-End Bearings Versions
- Simple Installation
- Wide Variety of Different Outputs; mVac, 0-5Vdc, 0-10Vdc, 4-20mA, $\pm 2.5\text{Vdc}$
- 3 Year Warranty



Image shows IP68 rated version with option R rod ends

The [AML/IE industrial LVDT displacement transducers](#) can be AC or DC powered and are sealed to IP65 as standard with the option of IP68 making them ideally suited for harsh and demanding applications where conditions are humid, wet, dusty or dirty. Typical applications include process plants, paper mills, and industrial test rigs.

The AML/IE industrial displacement transducers are constructed from stainless steel and fitted with a tough cable and can be supplied in a variety of mechanical configurations including captive guided core & extension rod, which is standard, plus spring-loaded core & extension rod with ball-end or guided core & extension with spherical rod-end bearings.

The AML/IE is supplied in a variety of packaging formats, enabling engineers to select quickly and precisely, the product required for a particular application.

An AC mV/V output is available as standard, with a range of DC voltage signal output options also offered including 0-5Vdc, 0-10Vdc and $\pm 2.5\text{Vdc}$, as well as a 3-wire 4-20mA current output, please speak to our technical sales team.

The AML/IE is supported with a versatile range of instrumentation to enable engineers to implement the sensor with the minimum of fuss within a system. Supporting instrumentation includes trip amplifiers, indicators, PC interfaces, rack systems, and more, please [contact us](#) to discuss your requirements.

Options:

- Variety of Mechanical Configurations Available
- Longer Cable Lengths
- Higher Temperature Versions
- Custom Design Versions Available
- $\pm 0.25\%$ Accuracy
- IP68 Sealing to 5bar (50 metres depth)
- Integral Bayonet Lock Connector
- Axial Cable Exit
- USB Version (via DSC-USB)
- Wireless Versions (via T24 instrumentation)
- Single or Multi-Channel PC-Based Monitoring & Data Logging System.

Applications:

- Process Plants
- Paper Mills
- Industrial Test Rigs
- Harsh & Demanding Applications (IP68)





Specification:

CHARACTERISTICS	AML/IE	AML/IEJ	AML/IEU	AML/IEU -10	AML/IEI	AML/IED	UNITS
Stroke Measurement Range:	±0.5, ±2.5, ±5, ±10, ±12.5, ±15, ±25, ±50, ±75, ±100, ±125, ±150, ±175, ±200, ±250 ±300, ±400, ±500, ±550 (maximum stroke is ±125 for Sprung Loaded Core & Extension)						millimetres
Signal Output:	See Table Below		0-5volt	0-10volt	4-20mA	±2.5volt	
No. of Wires	6	4	3	3	3	4	
Supply Voltage (unregulated):	2 to 5Vrms @ 1 to 5kHz		10-24Vdc	14-24Vdc	14-24Vdc	12Vdc regulated	
Supply Current:	-		35mA @ 15V	35mA @ 15V	35mA typ.	35mA @ 12V	
Max. Loop Resistance:	-		-	-	300 @ 30V	-	ohms
Max. Output Sink Current:	-		0.5	1	-	0.1	milliamps
Non-Linearity:	<0.50 (<0.25 optional)						±% Stroke Range
Repeatability:	<0.10						±% Stroke Range
Output Bandwidth (flat):	100		100	100	100	100	Hz
Output Ripple:	-		30mV max.	30mV max.	0.1% @ 20mA	30mV max.	
Operating Temperature Range:	AML/IE & IEJ: -30 to +85 Standard / -30 to +150 and +200 Optional -20 to +85 on DC/DC models / 0 to +70 for in-line conditioner (where fitted)						°C
Zero Temperature Coefficient:	<0.020					<0.010	±%Stroke Range/°C
Span Temperature Coefficient:	<0.020					<0.030	±%Stroke Range/°C
Vibration Resistance:	20g up to 2kHz						
Shock Resistance:	1000g for 10milliseconds						
Construction Materials:	Body & Extension Rod: 303 St/Steel, Core: 416 St/Steel, Cable Gland: Nickel-Plated Brass, Spring: 316 St/Steel, Rod-End Bearings: Mild Steel (St/Steel on IP68 version)						
Connecting Cable:	2 metre screened PVC cable* (*IP68 = PUR / Hi-Temp = PTFE).						
Environmental Sealing:	IP65 (IP68 optional)						
Note: On DC output version (0Vdc / 4mA) is given with the core in the extended / outwards position. This can be reversed if required, please request Option Y on your order.							

Industrial LVDT AC Version

Wiring AC Version:

4-wire AC Version (PVC or PTFE, High Temperature 150°C and 200°C)

Wire	Designation
 Red	Primary +ve
 Yellow	Primary -ve
 Blue	Secondary +ve
 Green	Secondary -ve
 Ground	Screen (not connected to sensor body)

Wiring AC Version continued:

6-wire AC Version (PVC)

Wire	Designation
Yellow	Primary +ve
Black	Primary -ve
Green	Secondary 1 +ve
Red	Secondary 1 -ve (centre tap)
White	Secondary 2 +ve
Blue	Secondary 2 -ve (centre tap)
Ground	Screen (not connected to sensor body)

6-wire AC Version (PTFE, High Temperature 150°C and 200°C)

Wire	Designation
Yellow	Primary +ve
Black	Primary -ve
Blue	Secondary 2 -ve (centre tap)
Brown	Secondary 2 +ve
Green	Secondary 1 +ve
Red	Secondary 1 -ve (centre tap)
Ground	Screen (not connected to sensor body)

Dimensions AC Versions (mm):

Stroke (mm)	Standard (Plain Core + Extension)	Standard and Option R (Rod End Bearings)				Option R (Rod End Bearings)		
	Body Length (mm)	Sensitivity @ 3kHz with 50K load (mV/V FRO)	NULL mV	Primary Resistance (ohms)	Secondary Resistance (ohms)	Body Length (mm)	M6 "L" (mm) (+50+18)	M8 "L" (mm) (+50+21)
±0.5	100	175	20	40	1800	100	168	171
±2.5	100	140	5	130	740	100	168	171
±5	115	135	5	48	108	120	188	191
±10	140	270	5	70	170	140	208	211
±12.5	160	195	5	120	190	160	228	231
±15	175	246	5	90	190	175	243	246
±25	235	225	5	130	210	235	303	306
±50	320	260	5	200	270	320	388	391
±75	390	390	20	260	460	390	458	461
±100	450	240	5	150	150	450	518	521
±125	500	260	5	180	320	500	568	571
±150	560	230	5	210	290	560	628	631
±175	615	260	2	230	360	615	683	686
±200	700	285	10	250	430	700	768	771
±250	810	310	10	290	560	810	878	881
±300	920	270	5	690	770	920	988	991
±400	1150	440	20	450	1010	1150	1218	1221
±500	1410	475	10	550	1530	1410	1478	1481
±550	1410	345	10	550	1530	1410	1478	1481

For sprung-loaded dimensions and outline drawing see page 6.

Dimensions AC (mm) continued:

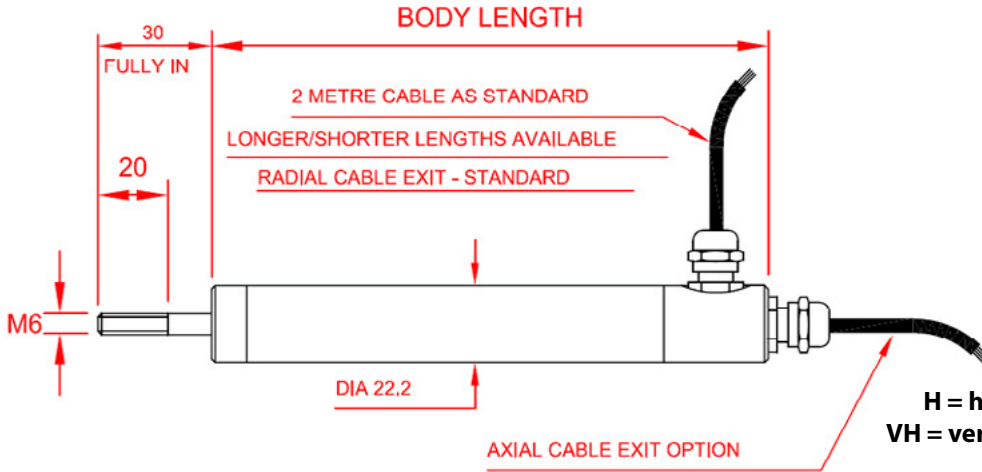

Plain Core + Extension AML-IE Industrial AC Version (mm)

Options:

- A = axial cable exit
- R = radial cable exit
- J = 4-wire device
- G = extension rod wiper
- W = waterproof IP68
- H = high temperature 150°C, with PTFE cable
- VH = very high temperature 200°C, with PTFE cable
- Z = armoured hose
- 024 = increased linearity, $\pm 0.25\%$

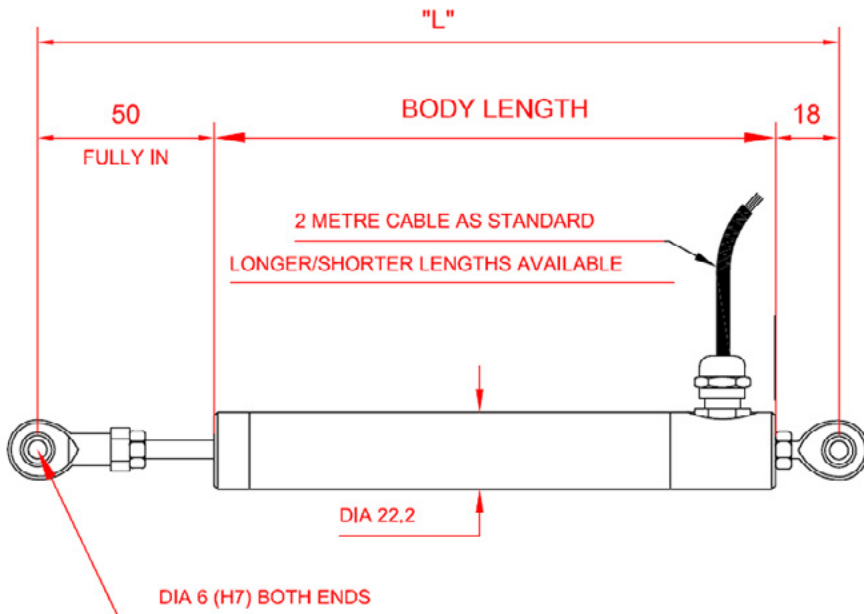

Option R M6 AML-IE AC Version with M6 Rod End Bearings (mm)

Options:

- R = radial cable only
- J = 4-wire device
- G = extension rod wiper
- W = waterproof IP68, with stainless steel M6 rod end bearings
- H = high temperature 150°C, with PTFE cable and stainless steel M6 rod end bearings
- VH = very high temperature 200°C, with PTFE cable and stainless steel M6 rod end bearings
- Z = armoured hose
- 024 = increased linearity, $\pm 0.25\%$

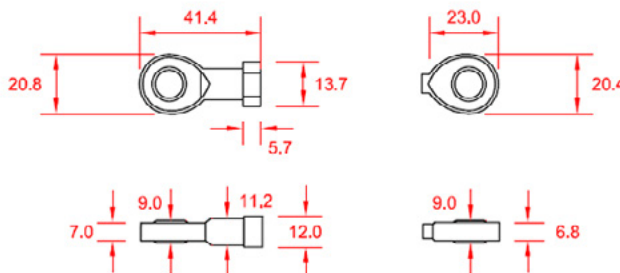

Axial cable exit is NOT available with rod ends unless rod end is on the extension ONLY

Dimensions AC (mm) continued:

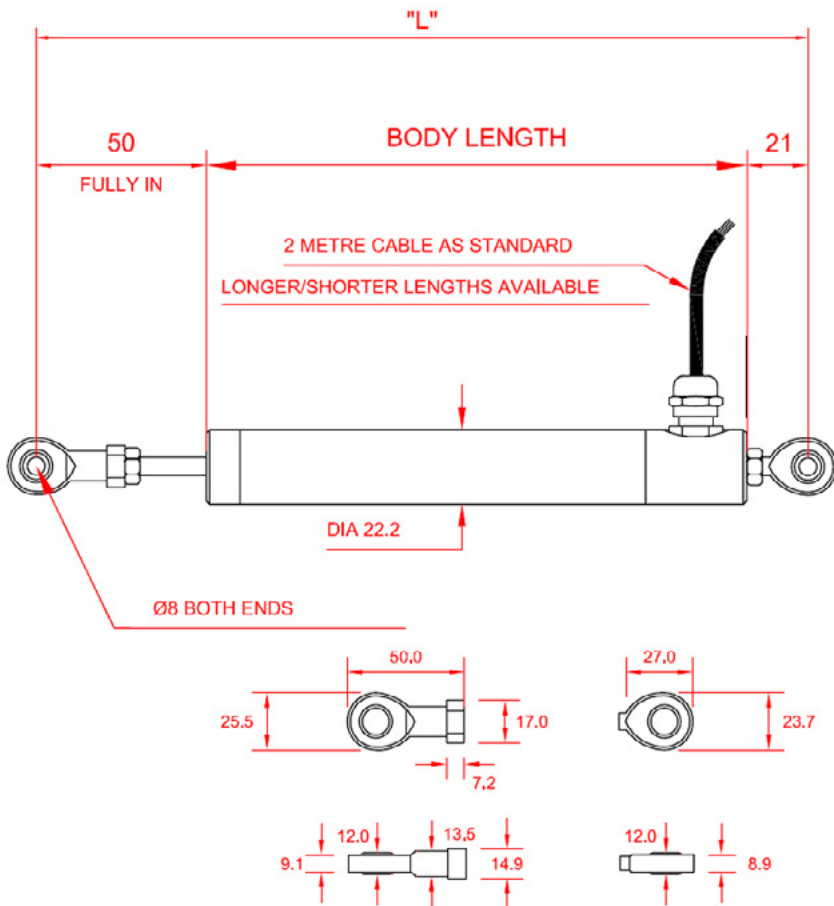

Option R M8 AML-IE AC Version with M8 Rod End Bearings (mm)

Options:

- R = radial cable only
- J = 4-wire device
- G = extension rod wiper
- W = waterproof IP68, with stainless steel M8 rod end bearings
- H = high temperature 150°C, with PTFE cable and stainless steel M8 rod end bearings
- VH = very high temperature 200°C, with PTFE cable and stainless steel M8 rod end bearings
- Z = armoured hose
- 024 = increased linearity, ±0.25%

Axial cable exit is NOT available with rod ends unless rod end is on the extension ONLY

Z = Armoured Hose

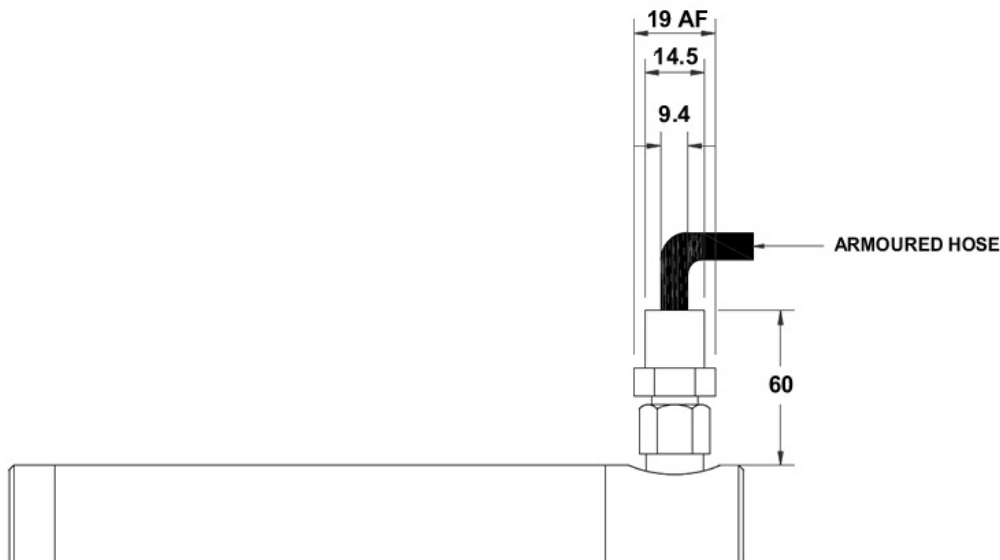

Dimensions AC (mm) continued:

Dimensions AC Sprung-Loaded Option S

Stroke (mm)	Body Length (mm)	Sensitivity @ 3kHz with 50K load (mV/V FRO)	NULL mV	Primary Resistance (ohms)	Secondary Resistance (ohms)	Spring Rate (N/mm)
±0.5	100	175	20	40	1800	0.2591
±2.5	100	140	5	130	740	0.2591
±5	115	135	5	48	108	0.1457
±10	160	270	5	72	138	0.0833
±12.5	160	195	5	72	138	0.0833
±15	175	246	5	90	190	0.0648
±25	235	225	5	130	210	0.0530
±50	320	260	5	200	270	0.0364
±75	390	390	20	260	460	0.0291
±100	440	240	20	260	460	0.0233
±125	525	260	5	145	230	0.0179

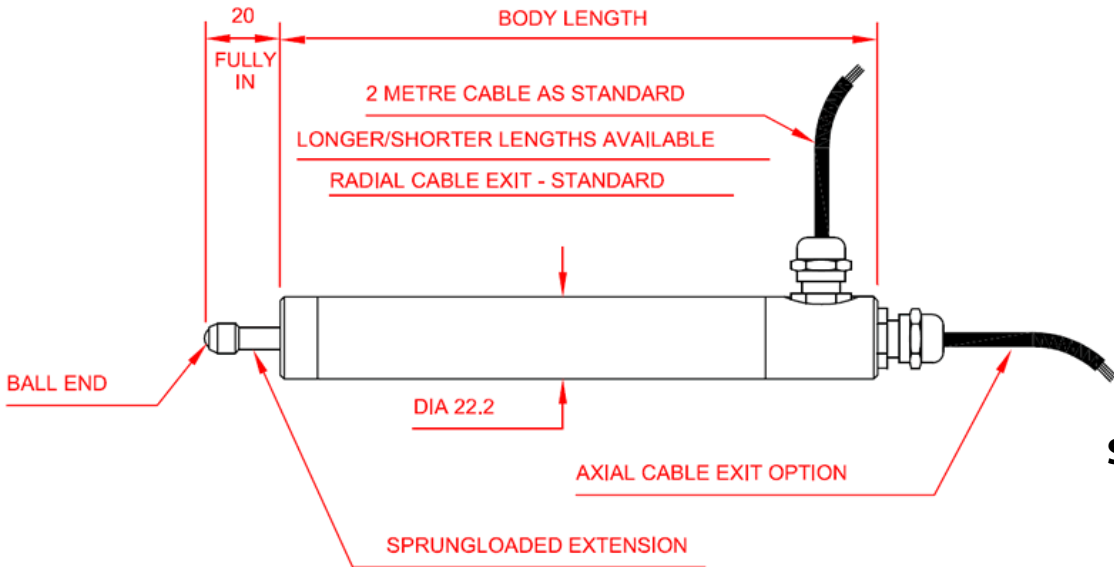

Option S AML-IE AC Version Sprung Loaded (mm)

Options:

R = radial cable

A = axial cable

J = 4-wire device

G = extension rod wiper

SW = waterproof IP68

H = high temperature 150°C, with PTFE cable

VH = very high temperature 200°C, with PTFE cable





Z = armoured hose

024 = increased linearity, ±0.25%

Industrial LVDT DC Version

Wiring DC Version:

3-wire DC Versions (4-20mA, 0-5Vdc, 0-10Vdc, ±2.5Vdc)

Wire	Designation
 Red	Supply
 Blue	0V common
 Green	Signal
 Ground	Screen (not connected to sensor body)

Dimensions DC Versions (mm):

Stroke (mm)	Standard	Option R (Rod End Bearings)		Option S (Sprung Loaded)		
	Body Length (mm)	Body Length (mm)	M6 "L" (mm) (+50+18)	M8 "L" (mm) (+50+21)	Body Length (mm)	Spring Rate (N/mm)
±0.5	130	130	198	201	130	0.1295
±2.5	140	140	208	211	140	0.1166
±5	165	165	233	236	165	0.0897
±10	180	180	248	251	180	0.0729
±12.5	210	210	278	281	210	0.0614
±15	225	225	293	296	225	0.0555
±25	285	285	353	356	285	0.0416
±50	370	370	438	441	370	0.0291
±75	440	440	508	511	440	0.0233
±100	500	500	568	571	440	0.0233
±125	550	550	618	621	525	0.0179
±150	610	610	678	681	n/a	n/a
±175	665	665	733	736	n/a	n/a
±200	750	750	818	821	n/a	n/a
±250	860	860	928	931	n/a	n/a
±300	970	970	1038	1041	n/a	n/a
±400	1200	1200	1268	1271	n/a	n/a
±500	1460	1460	1528	1531	n/a	n/a
±550	1460	1460	1528	1531	n/a	n/a

Dimensions DC Versions (mm) continued:

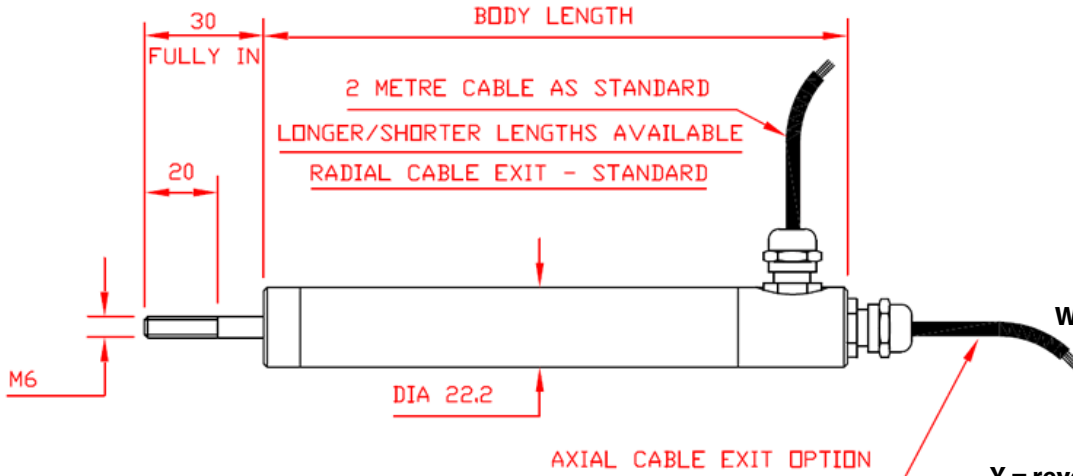

Plain Core AML-IE Industrial DC Version (mm)

Options:

- A = axial cable exit
- R = radial cable exit
- G = extension rod wiper
- W = waterproof IP68, with PU cable
- I = 4-20mA output
- U = 0-5V output
- U-10 = 0-10V output
- D = DC bipolar output
- Y = reverse output (e.g. 4mA fully in instead of default 20mA)
- Z = armoured hose
- 024 = increased linearity, $\pm 0.25\%$

H & VH = high temperature options not available

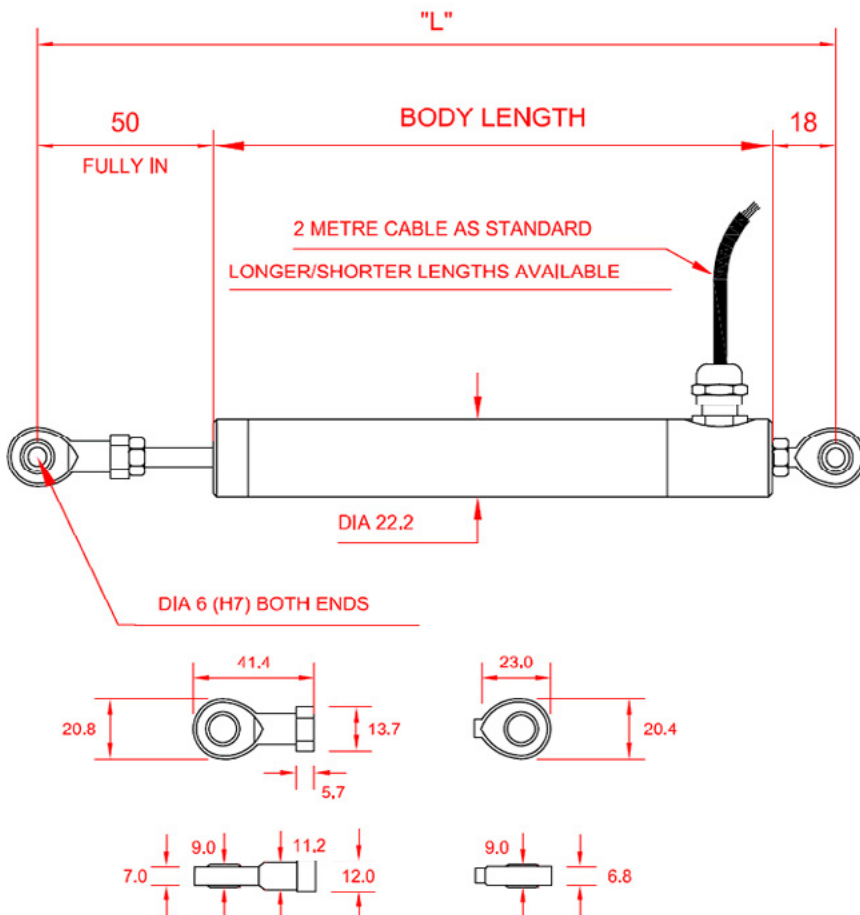

Option R M6 Rod Ends AML-IE Industrial DC Version with M6 Rod End Bearings (mm)

Options:

- R = radial cable exit only
- G = extension rod wiper
- W = waterproof IP68, with PU cable and stainless steel M6 rod end bearings
- I = 4-20mA output
- U = 0-5V output
- U-10 = 0-10V output
- D = DC bipolar output
- Y = reverse output (e.g. 4mA fully in instead of default 20mA)
- Z = armoured hose
- 024 = increased linearity, $\pm 0.25\%$

H & VH = high temperature options not available

Dimensions DC Versions (mm) continued:

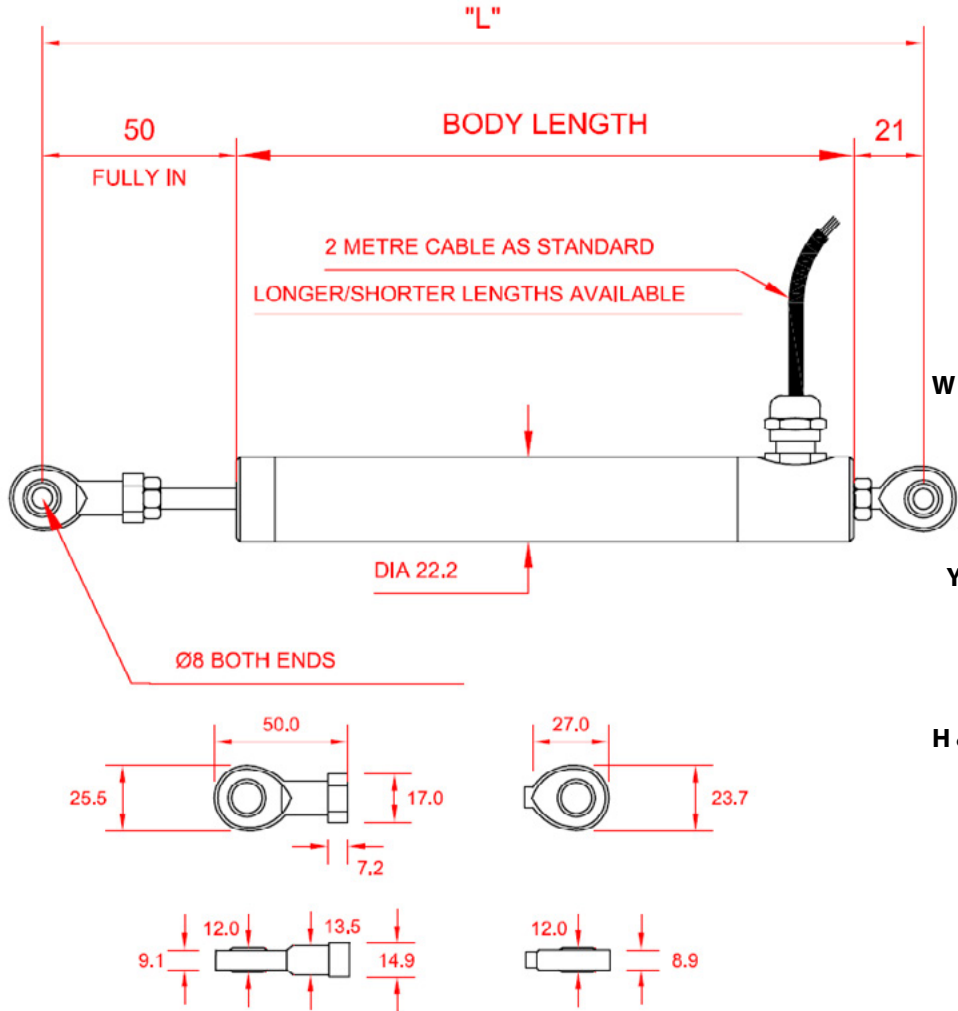

**Option R M8 Rod Ends
AML-IE Industrial
DC Version with
M8 Rod End Bearings
(mm)**

- Options:**
- R = radial cable exit only
 - G = extension rod wiper
 - W = waterproof IP68, with PU cable and stainless steel M8 rod end bearings
 - I = 4-20mA output
 - U = 0-5V output
 - U-10 = 0-10V output
 - D = DC bipolar output
 - Y = reverse output (e.g. 4mA fully in instead of default 20mA)
 - Z = armoured hose
 - 024 = increased linearity, $\pm 0.25\%$
- H & VH = high temperature options not available

**Option S
AML-IE Industrial
DC Version Sprung Loaded
(mm)**

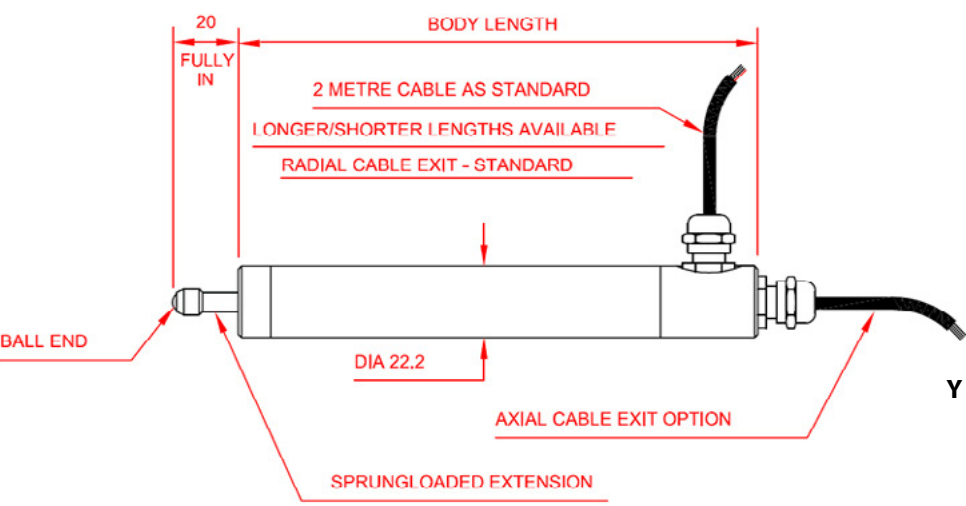

- Options:**
- R = radial cable exit
 - A = axial cable exit
 - G = extension rod wiper
 - W = waterproof IP68, with PU cable
 - I = 4-20mA output
 - U = 0-5V output
 - U-10 = 0-10V output
 - D = DC bipolar output
 - Y = reverse output (e.g. 4mA fully in instead of default 20mA)
 - Z = armoured hose
 - 024 = increased linearity, $\pm 0.25\%$
- H & VH = high temperature options not available

Dimensions DC Versions (mm) continued:

Optional In-Line Amplifier Housing Dimensions:

Required for high temperature versions with conditioned output. Can also be used with any AC version to give a DC output when minimum LVDT body length is required.

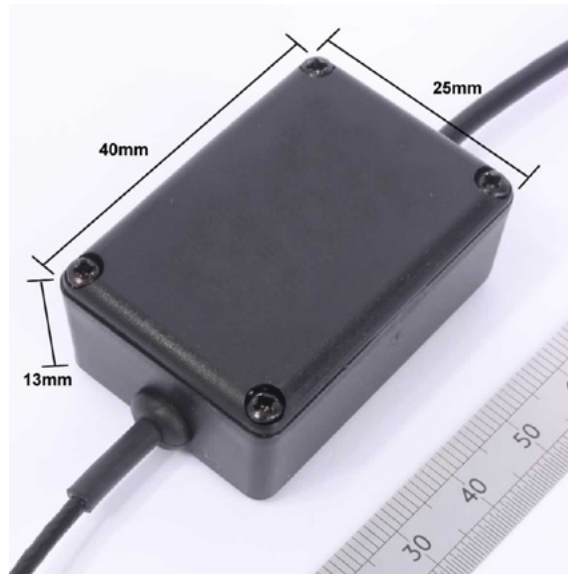

Associated Products:



[AML/M Miniature LVDT Displacement Sensor](#)



[Standard LVDT Displacement Sensor AML/E](#)



[INT4-P LVDT Digital Panel Meter](#)



[IL4-P Low Cost LVDT Indicator](#)

LVDTs, Displacement Sensors & Systems from the UK Experts

Ordering Codes:

AML/IEU10+/-500mm-WROA-0.2-000	AML/IE	U10	+/-500mm	-	WR	O	A	-	0.2	-	000
<i>Example Code</i>											
Product Family											
AML/IE	AML/IE										
Electrical Output											
Blank = 6-wire AC mV/V		Blank									
J = 4-wire AC mV/V		J									
U = 0-5Vdc		U									
U10 = 0-10Vdc		U10									
I = 4-20mA		I									
D = ±2.5Vdc (12Vdc regulated supply required)		D									
Stroke Range											
+/-0.5mm (0-1mm)			+/-0.5mm								
+/-2.5mm (0-5mm)			+/-2.5mm								
+/-5mm (0-10mm)			+/-5mm								
+/-10mm (0-20mm)			+/-10mm								
+/-12.5mm (0-25mm)			+/-12.5mm								
+/-15mm (0-30mm)			+/-15mm								
+/-25mm (0-50mm)			+/-25mm								
+/-50mm (0-100mm)			+/-50mm								
+/-75mm (0-150mm)			+/-75mm								
+/-100mm (0-200mm)			+/-100mm								
+/-125mm (0-250mm)			+/-125mm								
+/-150mm (0-300mm)			+/-150mm								
+/-175mm (0-350mm)			+/-175mm								
+/-200mm (0-400mm)			+/-200mm								
+/-250mm (0-500mm)			+/-250mm								
+/-300mm (0-600mm)			+/-300mm								
+/-400mm (0-800mm)			+/-400mm								
+/-500mm (0-1000mm)			+/-500mm								
+/-550mm (0-1100mm)			+/-550mm								
Mechanical Configuration											
G = Guided Core & Extension Rod					G						
S = Spring Loaded Core & Extension Rod with Ball-Tip (±125mm max range)					S						
SW = IP68 Rated to 5bar/50m with Spring Loaded					SW						
R = M6 Rod-End Bearings (with Guided Core)					R						
M8 = 8mm Core and Extension with M8 Male Thread					M8						
H = 150°C High Temperature Version with Guided Core (DC output requires in-line amplifier @ 70°C max)					H						
HR = 150°C High Temperature Version with M6 Rod-End Bearings					HR						
HR8 = 150°C High Temperature Version with M8 Rod-End Bearings					HR8						
VH = 200°C Very High Temperature Version with Guided Core (DC output requires in-line amplifier @ 70°C max)					VH						
VHR = 200°C Very High Temperature, M6 Rod End Bearings with Guided Core (AC output only)					VHR						

AML/IEU10+/-500mm-WR0A-0.2-000	AML/IE	U10	+/-500mm	-	WR	O	A	-	0.2	-	000
<i>Example Code</i>											
VHR8 = 200°C Very High Temperature Version M8 Rod End Bearings with Guided Core (DC output requires in-line amplifier @ 70°C max)					VHR8						
W = IP68 Rated - Waterproof/Submersible to 5bar External Pressure (50 metres) with Guided Core + Extension					W						
WR = IP68 Rated with M6 Rod-End Bearings - Waterproof/Submersible to 5bar External Pressure (50 metres)					WR						
WR8 = IP68 Rated with M8 Rod-End Bearings - Waterproof/Submersible to 5bar External Pressure (50 metres)					WR8						
<i>For the below configurations please speak to our technical team.</i>											
HS = 150°C High Temperature Version Spring Loaded Core & Extension Rod with Ball-Tip (±125mm max range) (DC output requires in-line amplifier @ 70°C max)					HS						
HSW = IP68 Rated to 5bar/50m with Spring Loaded 150°C High Temperature Version Spring Loaded Core & Extension Rod with Ball-Tip (±125mm max range) (DC output requires in-line amplifier @ 70°C max)					HSW						
VHS = 200°C Very High Temperature, Spring Loaded Core + Extension Rod with Ball Tip (±125mm max range) (AC output only)					VHS						
VHSW = IP68 Rated to 5bar/50m with Spring Loaded 200°C Very High Temperature Version Spring Loaded Core & Extension Rod with Ball-Tip (±125mm max range) (DC output requires in-line amplifier @ 70°C max)					VHSW						
HWR = 150°C High Temperature, IP68 Rated with M6 Rod-End Bearings - Waterproof/Submersible to 5bar External Pressure (50 metres) (AC output only)					HWR						
HWR8 = 150°C High Temperature, IP68 Rated with M8 Rod-End Bearings - Waterproof/Submersible to 5bar External Pressure (50 metres) (AC output only)					HWR8						
VHWR = 200°C Very High Temperature, IP68 Rated with M6 Rod-End Bearings - Waterproof/Submersible to 5bar External Pressure (50 metres) (AC output only)					VHWR						
VHWR8 = 200°C Very High Temperature, IP68 Rated with M8 Rod-End Bearings - Waterproof/Submersible to 5bar External Pressure (50 metres) (AC output only)					VHWR8						
Output Direction (only affects DC output versions)											
0 = Zero with core extended, Full Scale with core retracted						0					
Y = Full Scale with core extended, Zero with core retracted						Y					
Cable Exit Direction											
A = Axial (not available on rod-end bearing version)							A				
R = Radial							R				
Cable Length (in metres)											
02 = 2 metres (standard)									02		
0,2 = 0.2 metres									0,2		
10 = 10 metres									10		
02Z = 2 metres Armoured Hose									02Z		
10Z = 10 metres Armoured Hose									10Z		
Specials Code											
000 = No Special Requirements											000
024 = Improved ±0.25% accuracy											024
021 = Extension Rod Wiper											021